

# FLOOR LEVEL LIFTER

## THE STRONG AND CLEAN SOLUTION

### TECHNICAL SPECIFICATIONS

**NOTE: EVERYTHING CAN BE CUSTOMIZED FOR YOUR NEEDS**

- > LIFT CAPACITY: 1000 KG
- > TRAVEL: 900 MM.
- > CLOSED HEIGHT: 210 MM.
- > INSIDE LENGTH: 1220 MM.
- > INSIDE WIDTH: 1070 MM.
- > LENGTH: 1630 MM.
- > WIDTH: 1650 MM.
- > POWER SUPPLY: 3x400 V/50 Hz+PE  
OR 1x110 V/60 Hz+N+PE
- > CE AND UL CERTIFIED
- > STAINLESS STEEL AISI 304 AND 316
- > RUNS 10 LIFTS PER HOUR 8 HOURS A DAY (FULL TRAVEL)  
- PLEASE INQUIRE FOR INTENSIVE USE
- > 2 SAFETY LOCKS FOR MAINTENANCE
- > SAFETY TRIP BAR IN STAINLESS STEEL



The ergonomic stainless steel Floor Level Lift (FLL) is the perfect solution for limited floor space, heavy lifting and height variations in high sanitation environments.

The built-in ramp makes it highly innovative and makes the lift fit into the smallest of places with great access none the less. It will increase productivity and profits and prevent work related injuries caused by bending and lifting.

The combination of stainless steel and the FLL standard features makes this lifting table extremely sanitary and thus perfect for the food and pharmaceutical industries and corrosive environments.

The FLL is ideal for general materials handling, pallet loading and unloading and packing lines.

More information at [www.translyft.com](http://www.translyft.com)



The stainless steel solution makes it perfect for rugged conditions and the use of aggressive cleaning products like in the food industry.



It is easy loading or unloading pallets with the built-in ramp.



When stacking pallets the FLL helps to ensure that you are always working in the best ergonomic height.

TYPE / CAPACITY LBS	TRAVEL MM.	CLOSED HEIGHT MM.	TOTAL RAISED HEIGHT MM.	INSIDE LENGHT MM.	INSIDE WIDTH MM.	OUTSIDE LENGHT MM.	OUTSIDE WIDTH MM.	LIFTING TIME SEC.	WEIGHT KG
FLL 1000	900	210	1110	1220	1070	1630	1650	26	410

The FLL has a separate power unit.

## STANDARD FEATURES



The built-in ramp allows you to drive the pallets directly onto the lifting table.

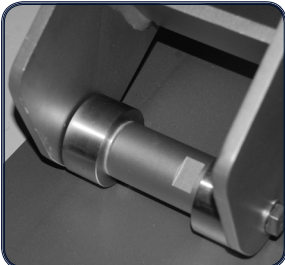

The bearings are approved by the FDA.



The safety trip bar removes the risk of jamming.

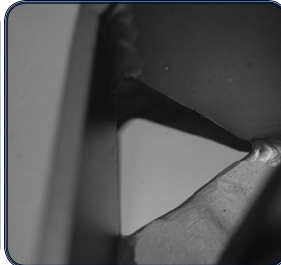

The drain holes makes the lifting table easier to clean.

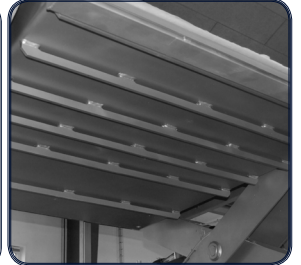

The reinforcements under the table strengthens the table.

Capacity	Highest load capability (when loaded correctly)
Travel (1)	Travel from closed height to top position
Closed height (2)	Height at lowest position
Total raised height (3)	Height at top position
Lenght (4)	Platform lenght
Width (5)	Platform width
Lift time	Time in sec. to top position
Motor	Size of motor
Weight	Weight of table

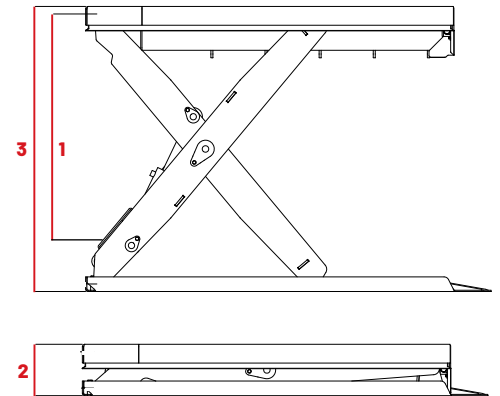
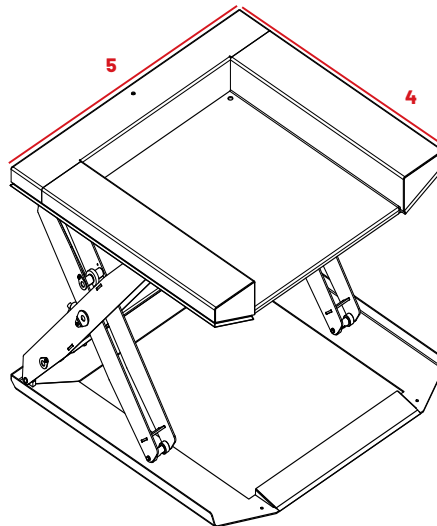

**Have any questions about dimensions or features? Please call us at +45 9886 4900 or find more information at [www.translyft.com](http://www.translyft.com)**